



RM-WCH-8 Firmware Update Instructions

■ Summary

After pairing the charger and access point for which operator wants to update the firmware, update the charger firmware, which is bundled in the access point firmware, to the charger over the air.

- [1] Log in to the Web-GUI of the access point using "RM Device Finder"
- [2] Pair the access point and charger
- [3] Update Charger firmware from Web-GUI
- [4] Unpair the access point and charger

■ Advanced Requirements

- 1 x Windows PC with wired ethernet connector
- 1 x PoE network switch
- LAN cable (CAT5e or higher)
- PC application "RM Device Finder"
- RM-WAP-8 (uploaded new firmware)

【Procedure for Logging in the Access Point's Web-GUI】

1. Execute RM Device Finder.exe and search for access points.

Double-clicking the Web-GUI icon of the access point to be paired with the charger from the listed access points displays the Web-GUI login screen. In that case, please confirm that the version of the access point is 1.8.2.

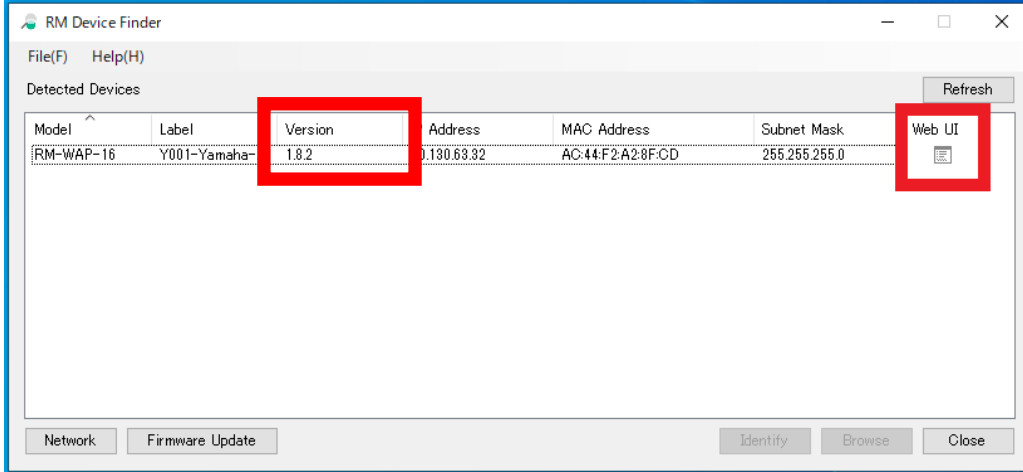

2. Set the Web-GUI login password.

Operator will need to set a password when logging in for the first time.



3. Login to Web-GUI.

After setting the password, log in using the set password.

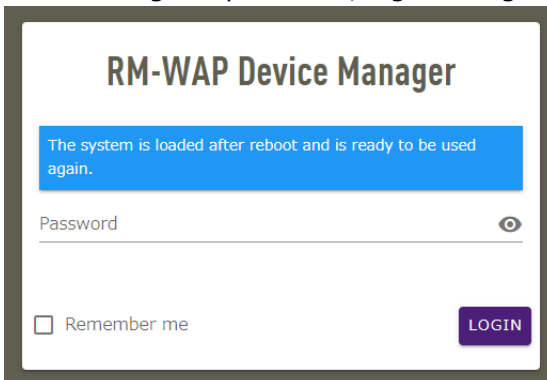

[Pairing Procedure]

1. Click the "PAIR NEW" button on the SETTINGS>CHARGER page.

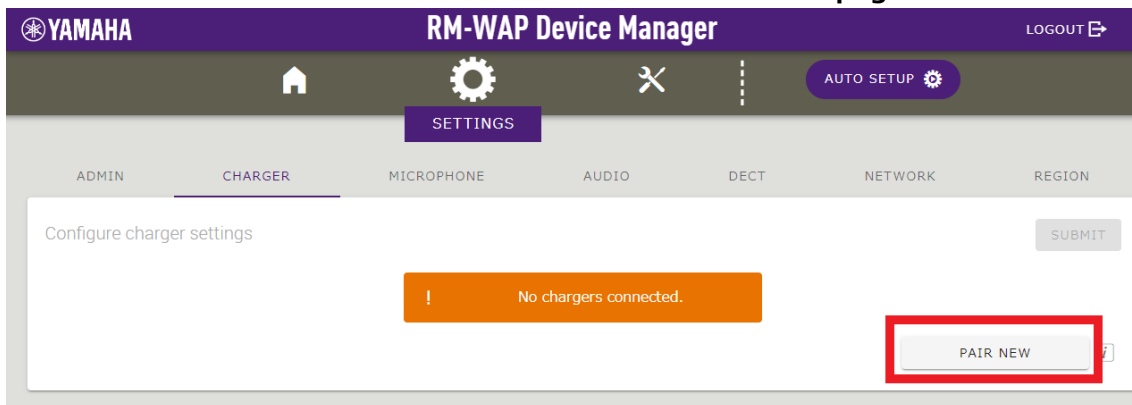

The access point will wait for pairing from the charger. At this time, the status indicator of the access point itself blinks blue.

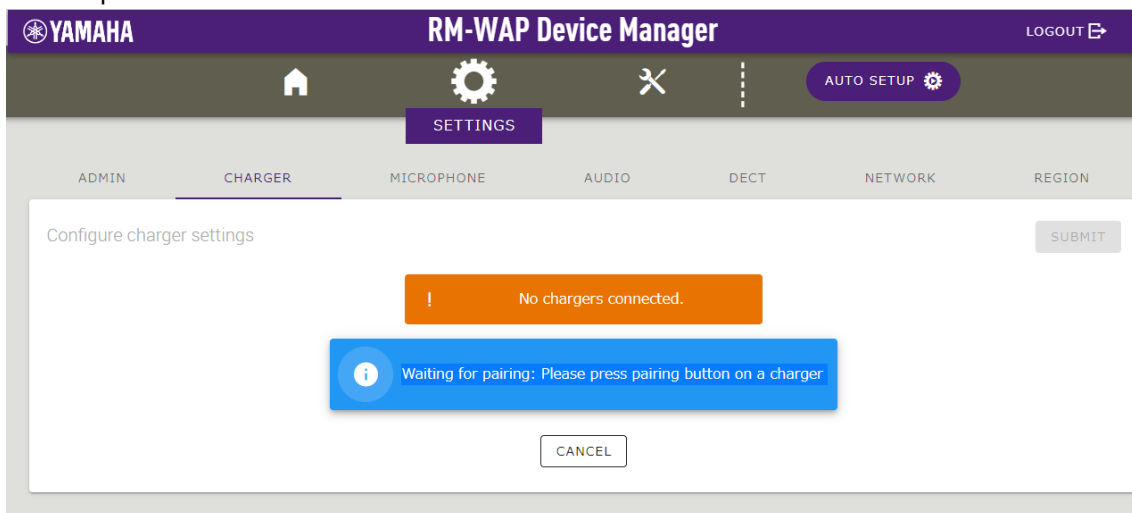

2. Press and hold the “PAIR” button for 2 seconds or more after starting the charger.

The ACTIVATE indicator on the charger will blink in blue rapidly to initiate pairing. When pairing is completed, it will blink twice in blue slowly and return to its original state.

【底面】

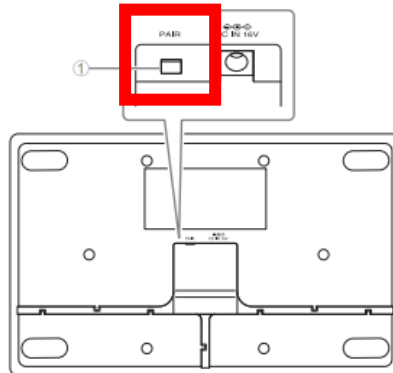

① PAIR ボタン

操作	ACTIVATE インジケータ	本製品の状態
PAIR ボタンを 2 秒以上長押しする	青色に高速で点滅	ペアリング待機状態 / ペアリングしている途中
PAIR ボタンを 2 秒以上長押しする	(青色に高速で点滅したあとに) 青色に 2 回点滅	ペアリングに成功した
PAIR ボタンを 2 秒以上長押しする	(青色に高速で点滅したあとに) 赤色に 2 回点滅	ペアリングに失敗した

RM-WCH-8

【天面】

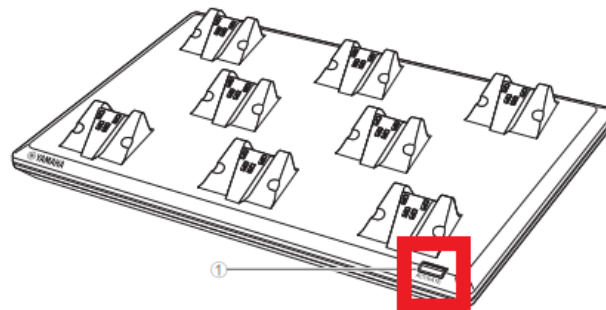

3. Once pairing is completed, the charger will be listed.

✓ indicates the updated state, ⚙ indicates that an update is required.

If pairing fails or if the pairing waiting state is canceled (pairing was not completed within 120 seconds), proceed to step 1. Please start over.

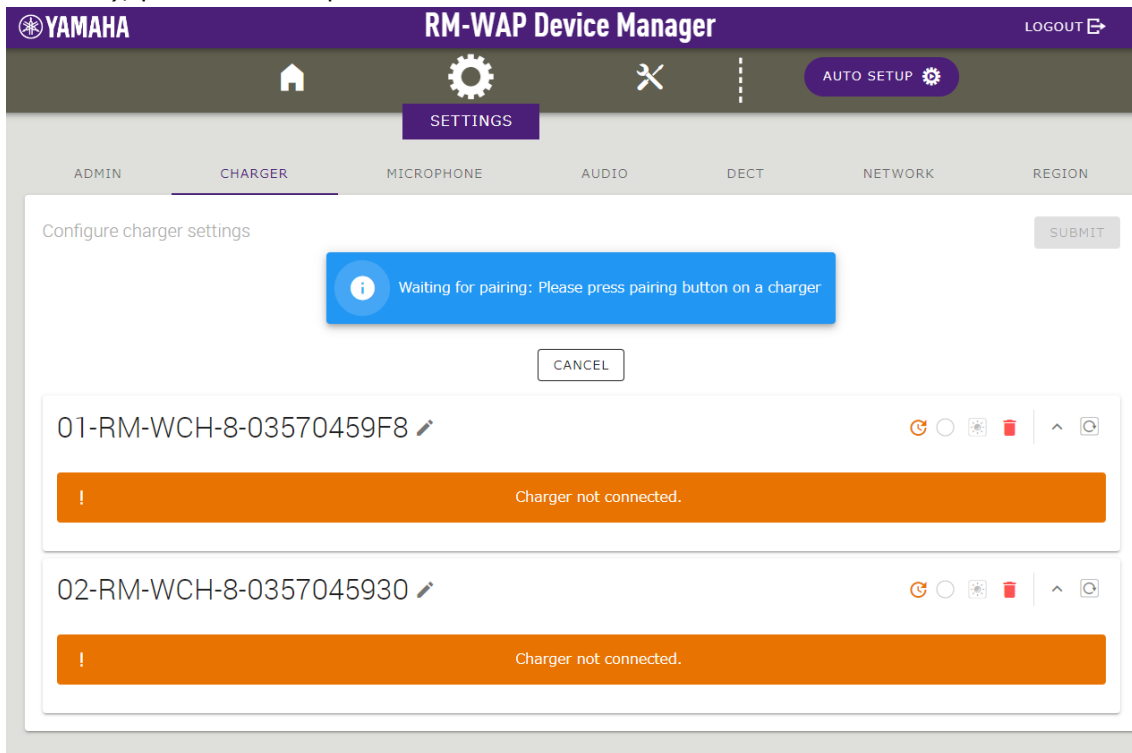

4. Click the “CANCEL” button on the SETTINGS>CHARGER page.

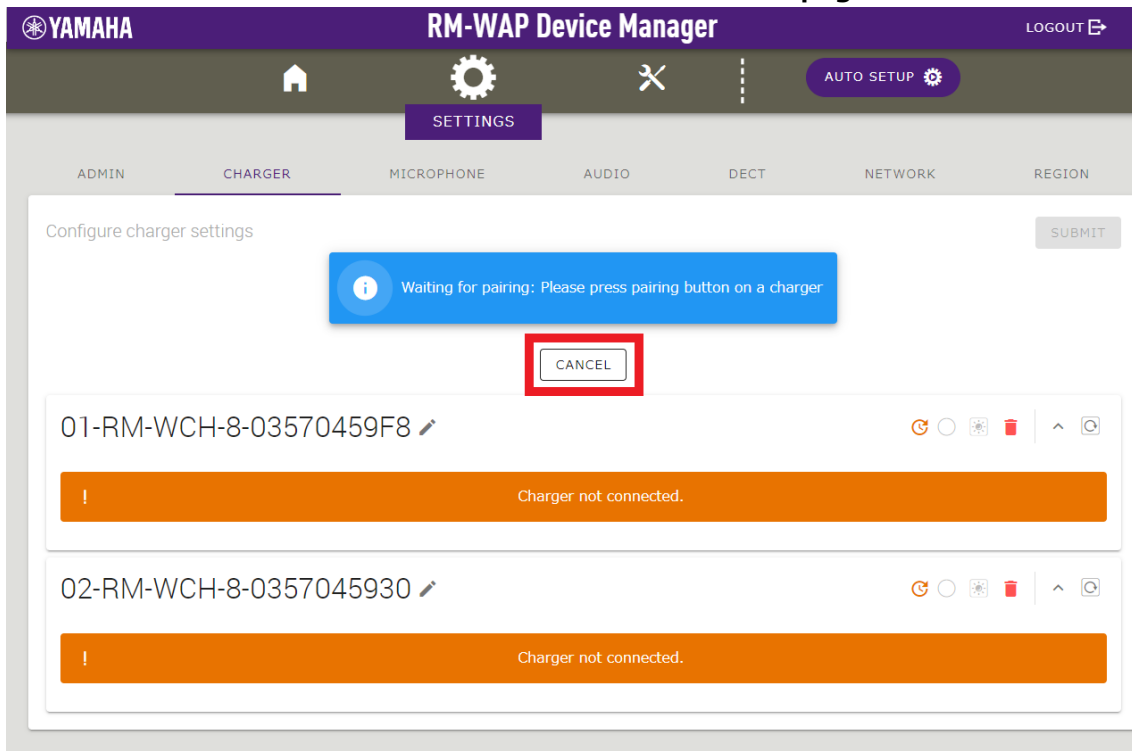

Pairing is now completed.

The screenshot shows the Yamaha RM-WAP Device Manager interface. At the top, there is a purple header with the Yamaha logo and the text 'RM-WAP Device Manager'. Below the header is a navigation bar with icons for Home, Settings, and a menu. The 'SETTINGS' menu is active, and the 'CHARGER' sub-menu is selected. The main content area is titled 'Configure charger settings' and contains two device entries. Each entry has a unique ID, a status bar indicating 'Charger not connected.', and a 'PAIR NEW' button. The status bars are orange with a white exclamation mark icon.

ID	Status
01-RM-WCH-8-03570459F8	Charger not connected.
02-RM-WCH-8-0357045930	Charger not connected.

[Firmware Update Procedure]

1. Click the "TURN ON FWU MODE" button on the TOOLS>UPDATE page.

Click this button to change to firmware update only mode and stop audio communication between the access point and the microphone. When the firmware update is completed, click the "TURN OFF FWU MODE" button to release the dedicated mode.

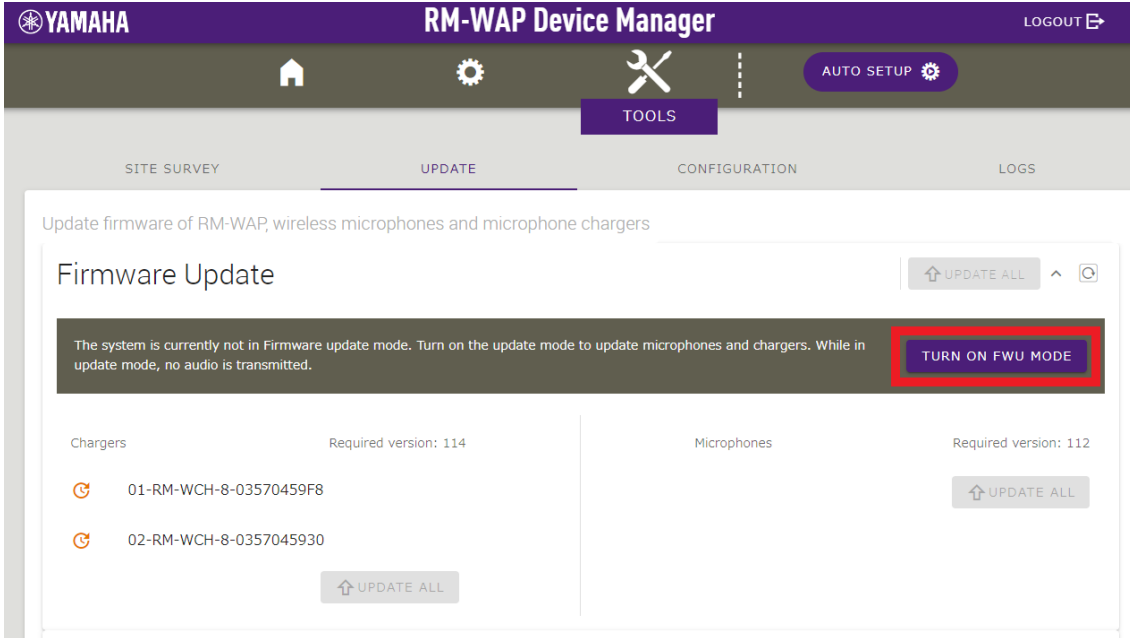

2. Click the "UPDATE ALL" button.

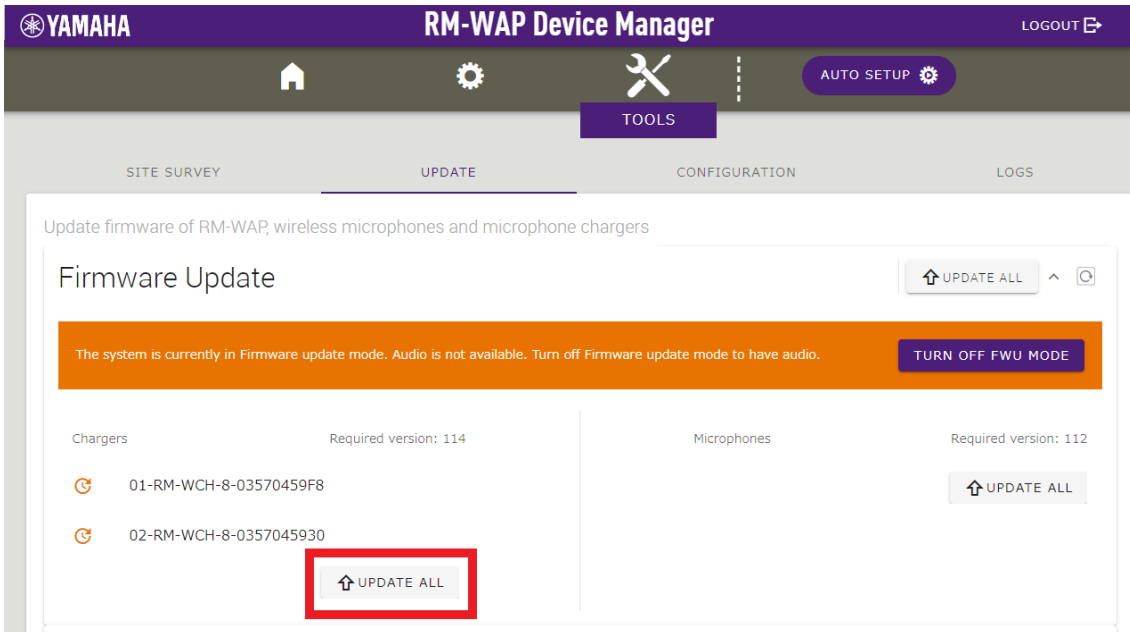

Charger update will start. Only chargers that need updating will be updated. The charger has two types of firmware, the charger firmware is written first (approximately 1 minute 30 seconds), and then the microphone firmware is written (approximately 2 minutes 30 seconds). If multiple chargers are paired, write the charger firmware to all chargers before writing the microphone firmware.

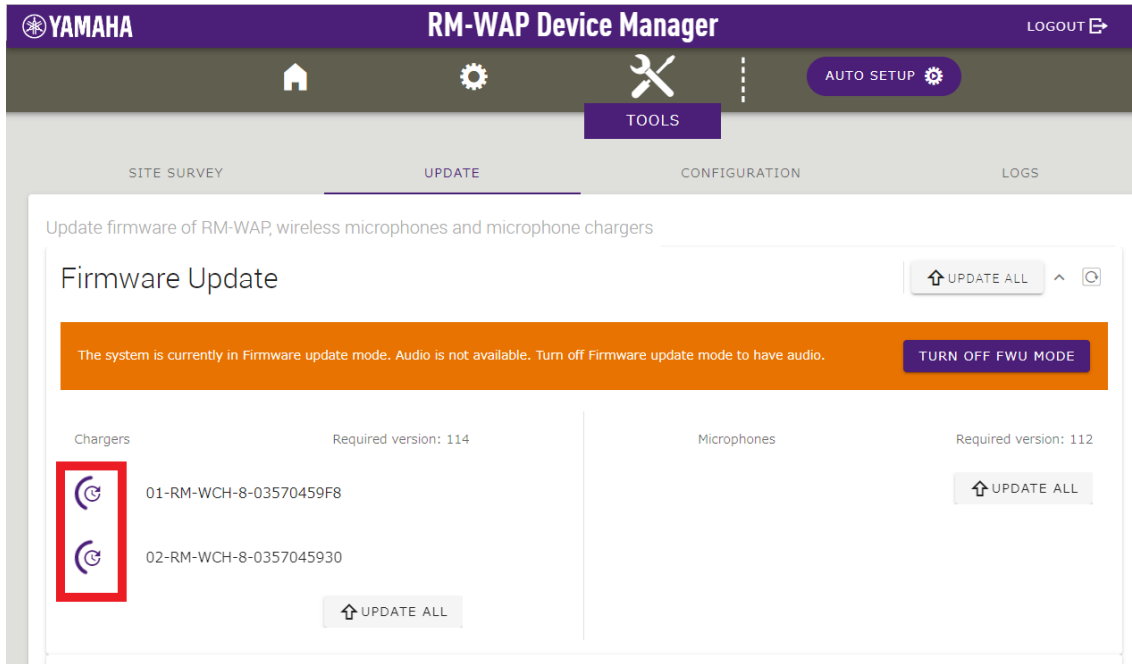

The status will change when the update is completed.

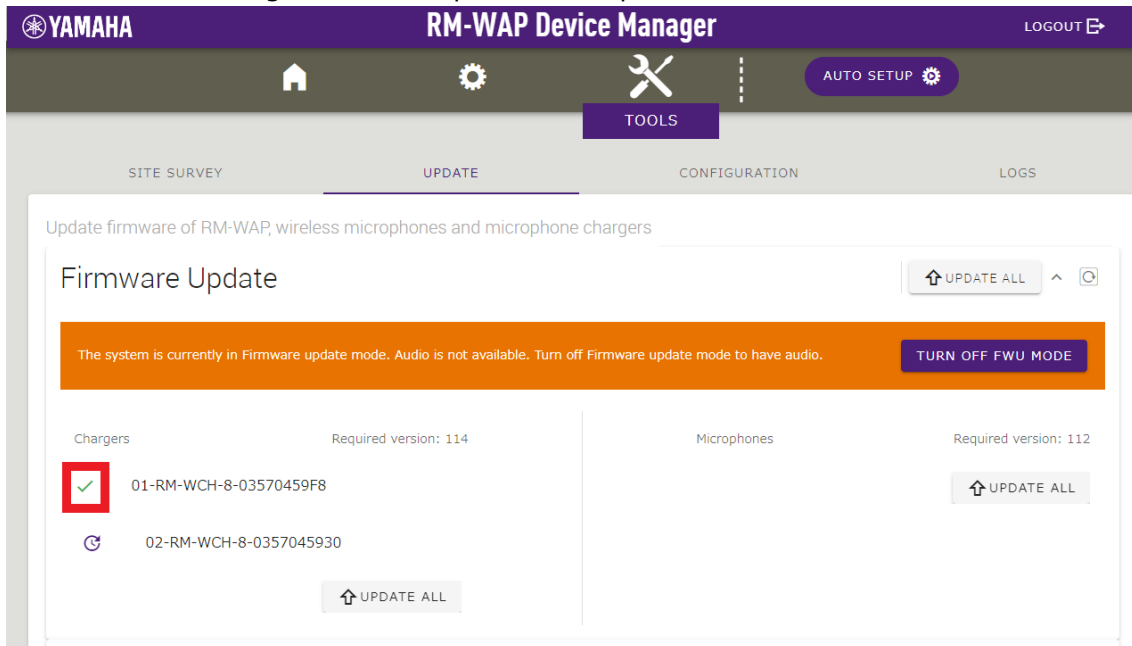

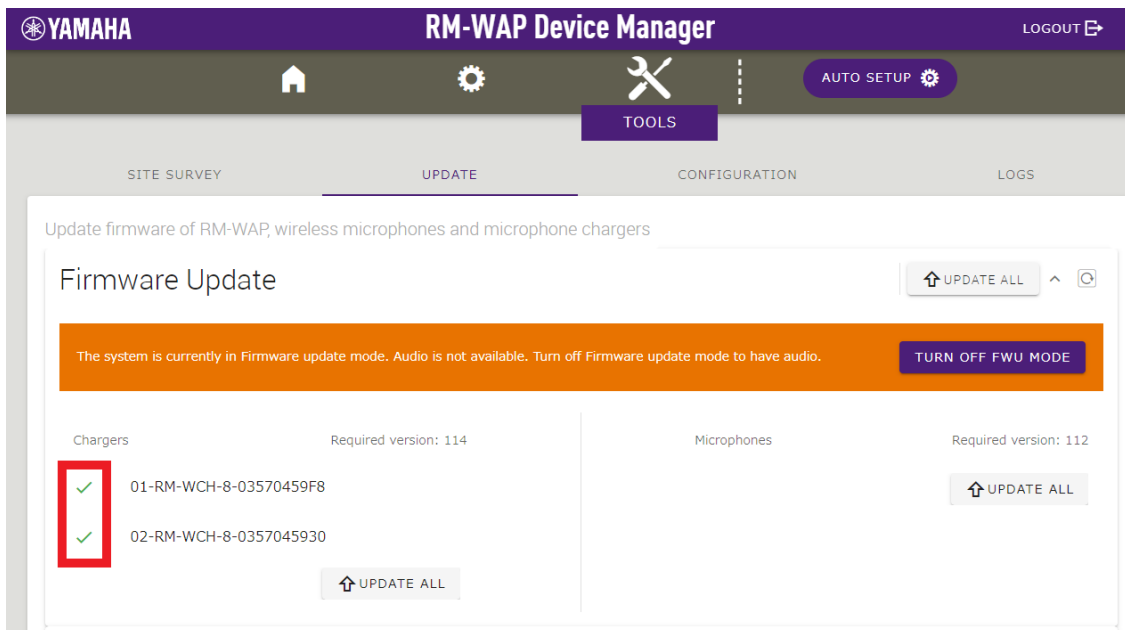

Operator can check the status of the firmware update on the charger itself with the **ACTIVATE** indicator.

RM-WCH-8

[Top panel]

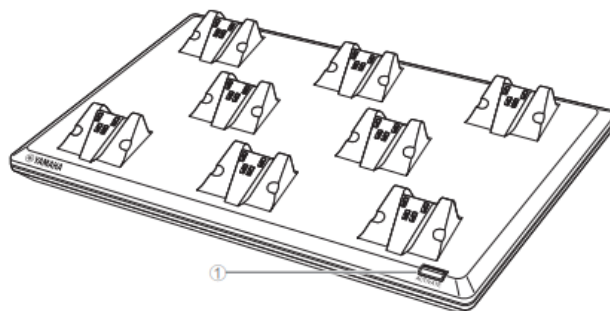

① ACTIVATE button/indicator

Condition	ACTIVATE indicator	Unit status
Power plug inserted into electrical outlet	Lit green	Operating
ACTIVATE button long-pressed for at least 2 seconds	Flashes blue quickly	Waiting for pairing/Pairing of access point and microphone(s)
ACTIVATE button long-pressed for at least 2 seconds	(After flashing blue quickly) Flashes blue twice	Access point and microphone(s) paired successfully
ACTIVATE button long-pressed for at least 2 seconds	(After flashing blue quickly) Flashes red twice	Pairing of access point and microphone(s) failed
Identifying in Web GUI failed	Flashes white	Proceeding to identify function
Updating firmware	Flashes white quickly	Firmware being updated
Updating firmware	(After flashing white quickly) Flashes white twice	Firmware updated successfully
Updating firmware	(After flashing white quickly) Flashes red twice	Firmware update failed
—	Flashes red quickly	System error occurring

3. After confirming that the firmware has been updated, click the “TURN OFF FWU MODE” button.

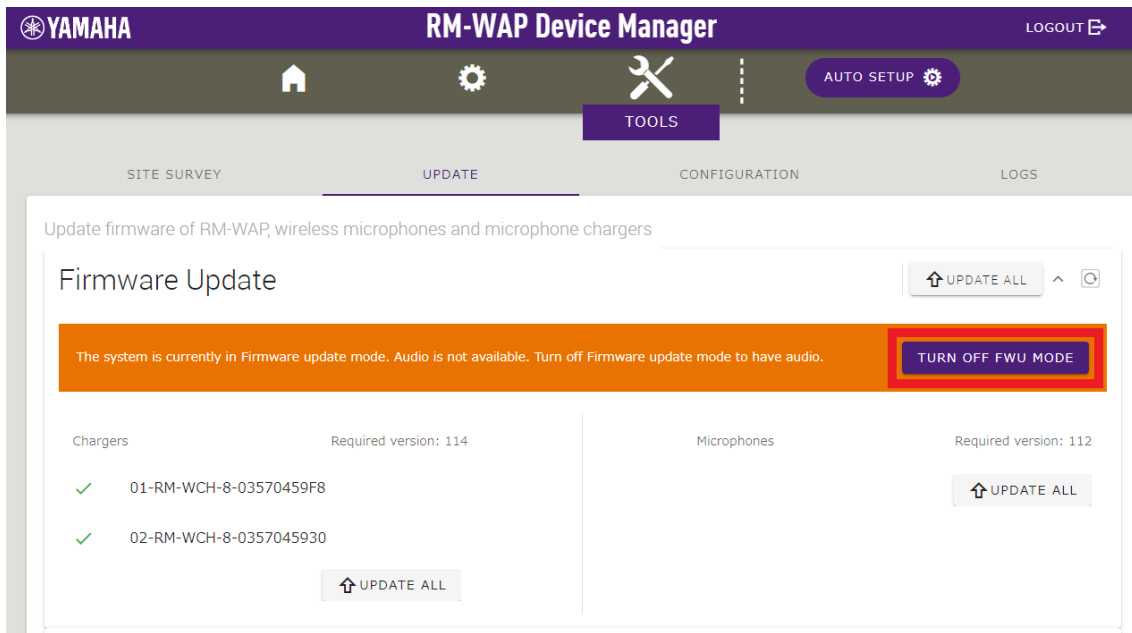

Firmware update is now completed.

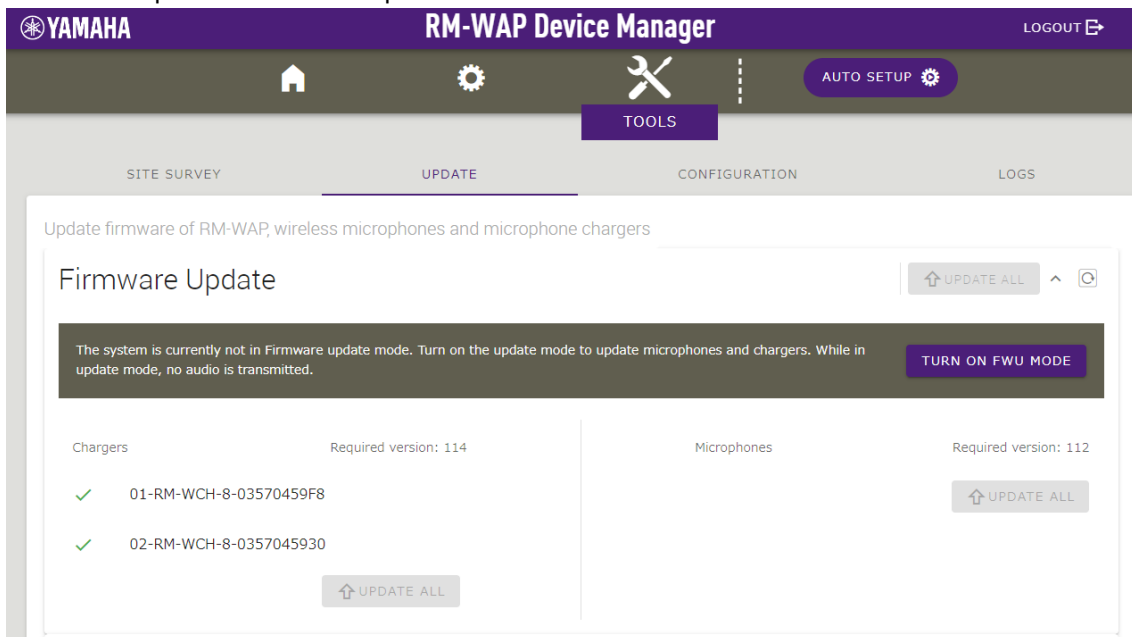

[Unpairing Procedure]

1. Click all “ ” icons on the SETTEINGS>CHARGER page.

Unpair all paired chargers for the next charger firmware update.

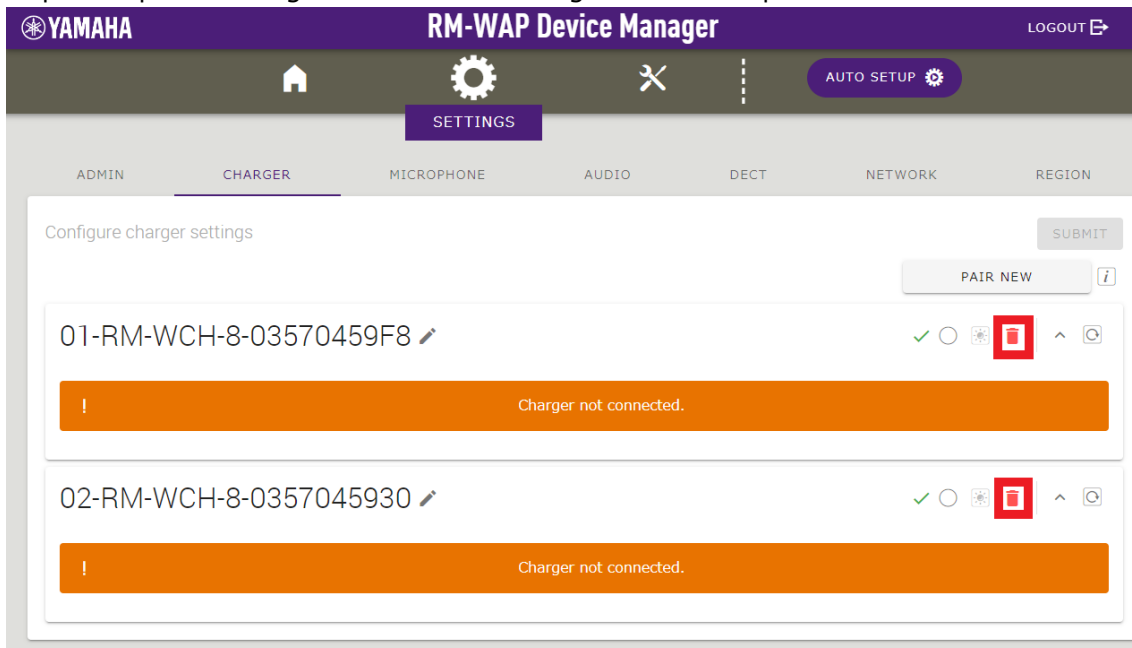

The screenshot shows the 'RM-WAP Device Manager' interface. The top navigation bar includes 'YAMAHA', 'RM-WAP Device Manager', and 'LOGOUT'. Below this is a secondary navigation bar with icons for Home, Settings, and Auto Setup. The 'SETTINGS' menu is expanded, showing options for ADMIN, CHARGER, MICROPHONE, AUDIO, DECT, NETWORK, and REGION. The 'CHARGER' section is active, displaying 'Configure charger settings' with a 'SUBMIT' button. Two chargers are listed:

- Charger 01: ID '01-RM-WCH-8-03570459F8'. It has a status bar that says 'Charger not connected.' and a red square unpairing icon highlighted with a red box.
- Charger 02: ID '02-RM-WCH-8-0357045930'. It also has a status bar that says 'Charger not connected.' and a red square unpairing icon highlighted with a red box.

Unpairing is completed when all charger names are removed from the list.

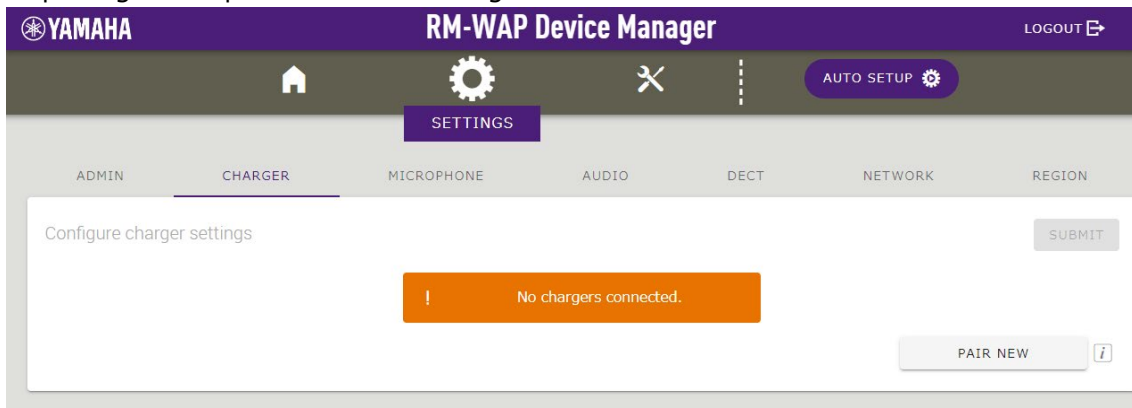

The screenshot shows the same 'RM-WAP Device Manager' interface. The 'CHARGER' section now displays 'Configure charger settings' with a 'SUBMIT' button and a central orange box that says 'No chargers connected.' The 'PAIR NEW' button is visible at the bottom right.

■ Summary

According to the RM-WCH-8 firmware update procedure to update the RM-WCH-8 to the latest firmware. If operator pus the microphone on the charger, the upgrade will start.

[Procedure]

1. Place the microphones on the charger in order from the first port.

Up to 8 microphones can be used at one time.

Firmware updates are executed in order from 1 to 8. It takes about 1 minute per unit.

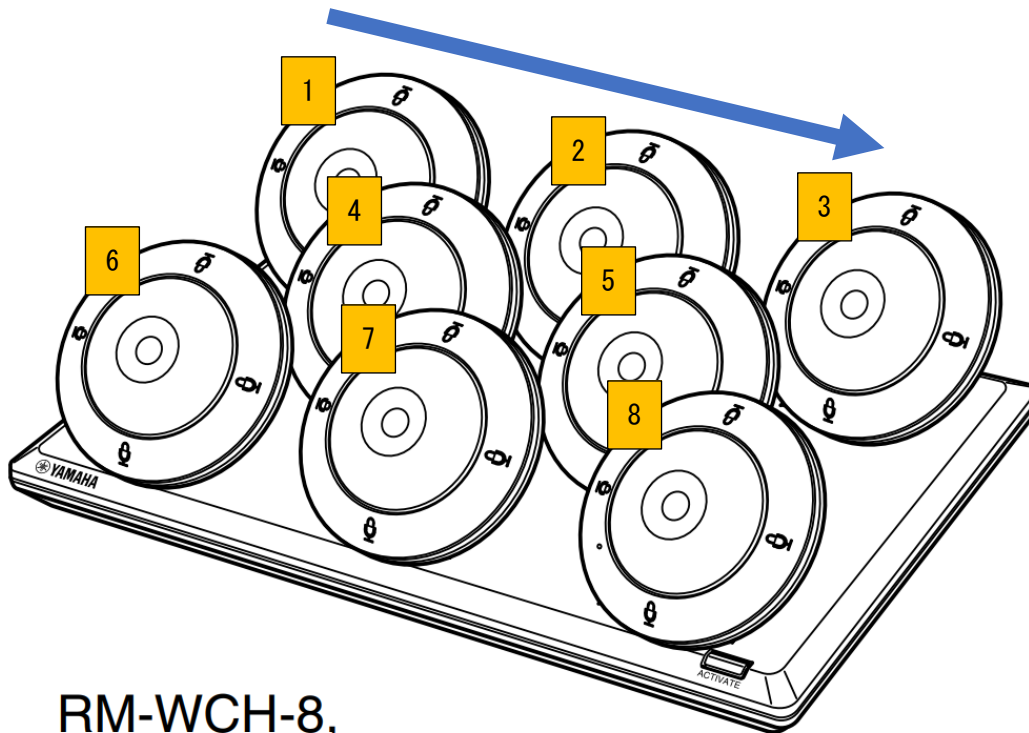

RM-WCH-8,
RM-WOM/RM-WDR/RM-WGL/RM-WGS

2. Wait for the firmware update of the last placed microphone to complete. After confirming the completion of the last microphone firmware update, return to 1) and perform the next firmware update.

Operator can check the status of the firmware update on the microphone itself with the MIC indicator. If the update completion cannot be confirmed by the microphone indicator, place the microphone on the charger again and check that the update does not start.

RM-WOM RM-WDR

[Top panel/side panel]

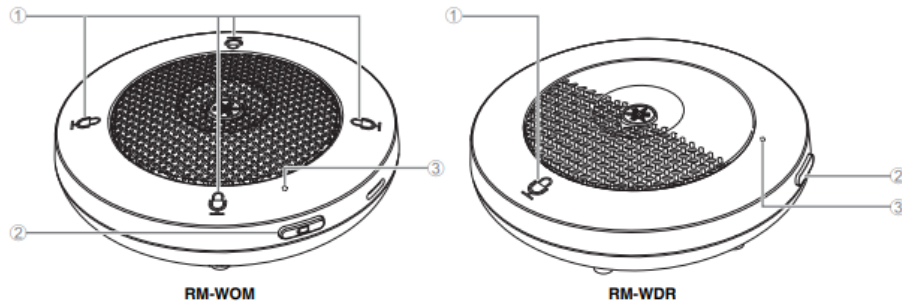

① Mic buttons/indicators

Condition	Mic indicator	Unit status
Mic button touched	Lit green	Microphone on
Mic button touched	Lit red (Flashes every 2 seconds)	Microphone off
Identifies in Web GUI of host	Flashes white	Responding (to identification)
Updating firmware	Flashes white quickly	Firmware being updated
Updating firmware	(After flashing white quickly) Flashes white twice	Firmware updated successfully
Updating firmware	(After flashing white quickly) Flashes red twice	Firmware update failed
-	Flashes red quickly	System error occurring
-	Flashes red slowly	Out of range for DECT connection